

Installation and maintenance sheet (Lock LRCE)

Including :

Compact electric door lock with central or lateral positive safety locking :	page 1
Technical characteristics - Operating instructions :	page 2
Wiring electrical contacts :	page 3
Main control system :	page 4
Accessories :	page 5
Examination certificate EC type :	page ...

Lock LRCE

Compact electric door lock with central or lateral positive safety locking

Central positive safety mechanism

réf : LRCE-PEC/ED

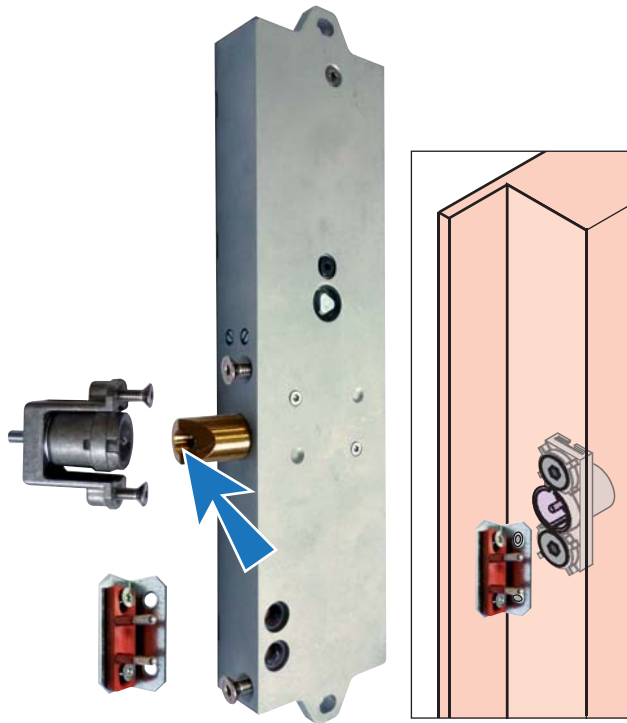

Lateral positive safety mechanism

réf : LRCE-PEL/ED

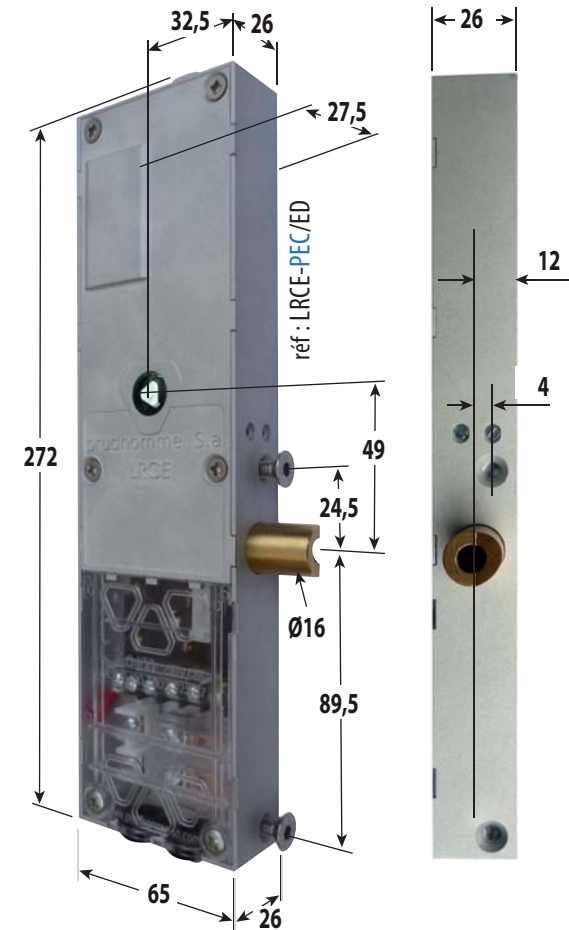
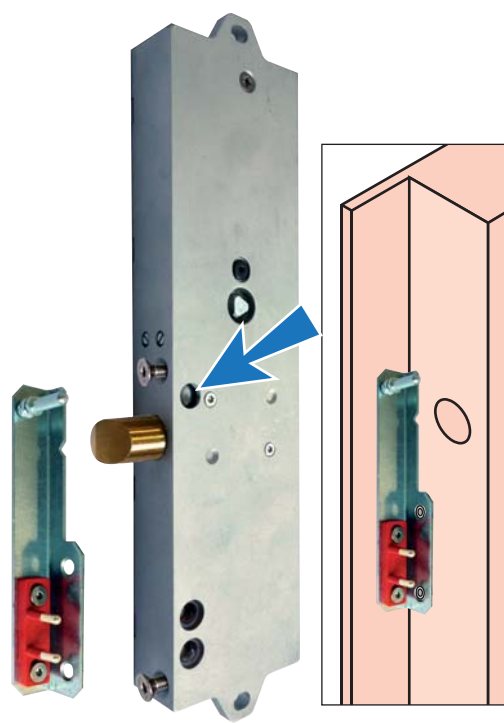

Lock LRCE

Technical characteristics - Operating instructions

Practically silent electric lock, with very low current and high unlocking-torque, driven by an electric stepper motor from the robotics industry.

Operating instructions

Electric:

1. The input voltage has to be DC stabilized current (either 12V, 24V, 48V depending on the model you ordered).

Note : If you are rectifying AC current, you also need to add a capacitor in line (series) to "stabilize" the current wave.
We suggest a 4700uF/50V capacitor.

2. The lock is protected for reverse polarity.
3. The lock is protected for over-current up to 60 volts DC (or 40V AC).

Safety:

1. The lock has a safety feature in case the bolt is blocked / held :
 - . The lock will pause and then reiterate the pulling sequence 3 times at a higher torque setting.
 - . Following the 3 pulling reiterations, if the bolt has not fully moved to its fully retracted position the lock will stop pulling to prevent damage and wait for the lift problem to be resolved.
 - . To reset the lock you simply need to cut and reset the power.

Certification

This component has obtained the EC examination certificate N° : NL 16-400-1002-125-07.

Protection-class

On request, the lock LRC E can be supplied in IP54 protection (Q3 2020)

Compact dimensions

- width 65mm
- thickness 26mm (27,5 mm at the bump over motor)

Silent : very low noise signature

Drive mechanism :

- Powerful professional stepper motor.
- Managed by micro controller.
- Direct drive solid gear mechanism.

Safety features :

- Bolt travel end limit detection with fast recovery algorithm

Maintenance

- Maintenance Free.

Energy :

- Available voltage : 12 Vdc - 24 Vdc - 48 Vdc (DC stabilized)
- Very low consumption
- Pulling current < 0,45 A (for 24V DC)
- Holding current < 0,20 A

Functioning :

Nominal voltage (dc)	12 V	24 V	48 V
Maximal voltage (dc)	18 V	36 V	55 V
Minimal voltage (dc)	10,8 V	18 V	36 V
Pulling current	0,85 A	0,45 A	0,3 A
Holding current	200 mA	150 mA	150 mA
Max ambient temperature	-25°C to + 70°C		
Storage temperature	-40°C to + 80°C		
Unlocking time	≈ 300 ms		
Max cycle	240 / hr		
Weight	1,37 Kg		
Protection class	IP4X (option IP54) (Q3 2020)		



Lock LRCE

Wiring electrical contacts

This is a **RIGHT LOCK**
Right Lock = Bolt on right side when viewing top window of lock and electric cable outlet towards bottom.
Left Lock = bolt is on opposite side and all contacts are reversed.

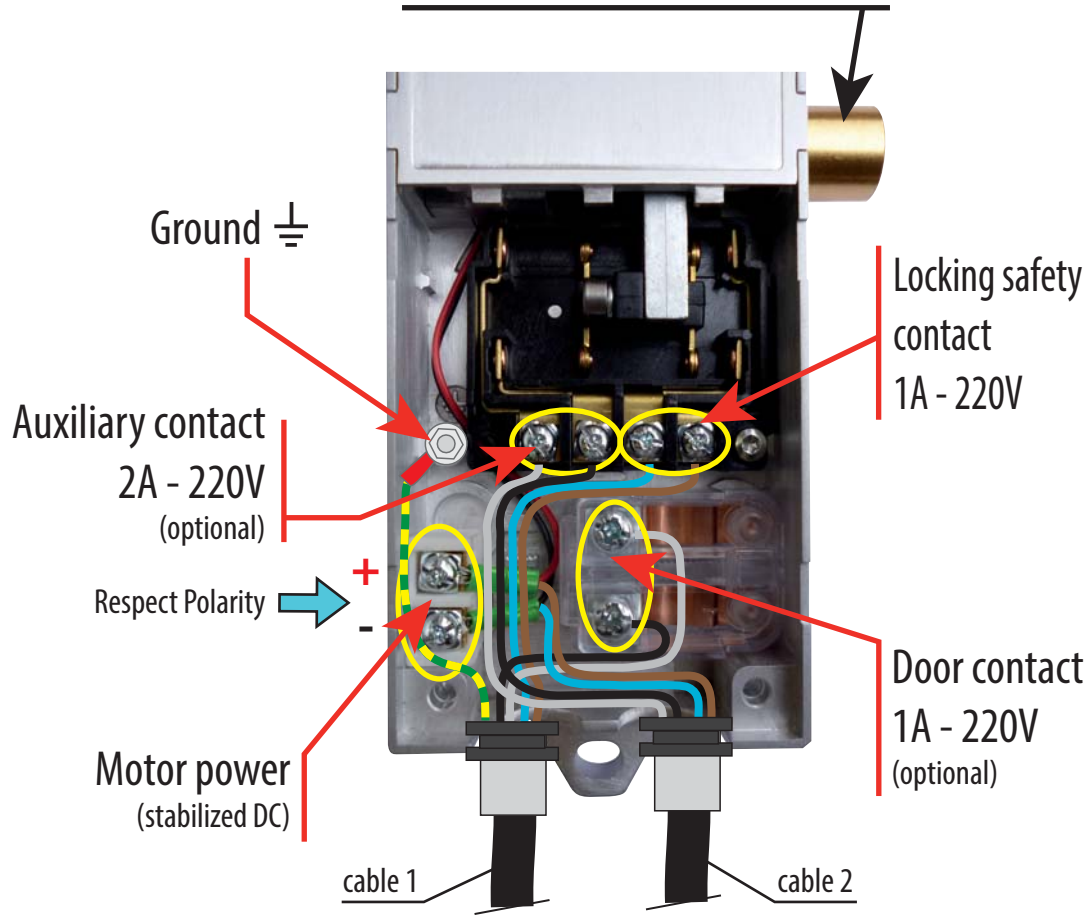

Contacts (prudhomme S.a pre-wiring)

Cable 1	Cable 2 (pin side)
blue } Locking safety contact	(+) = red = brown } motor
brown } Locking safety contact	(-) = black = blue } motor
gray } Door contact	gray } Auxiliary contact
black } Door contact	black } Auxiliary contact
green/yellow : \perp	

Caution !
 - DC stabilized current only
 - Respect polarity

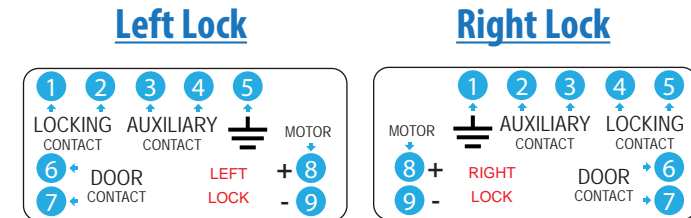

Locks LRCE

Main control system

RCD 180 :

inter. Positiv for positiv lock LR128 or LR180 E or LRCE.

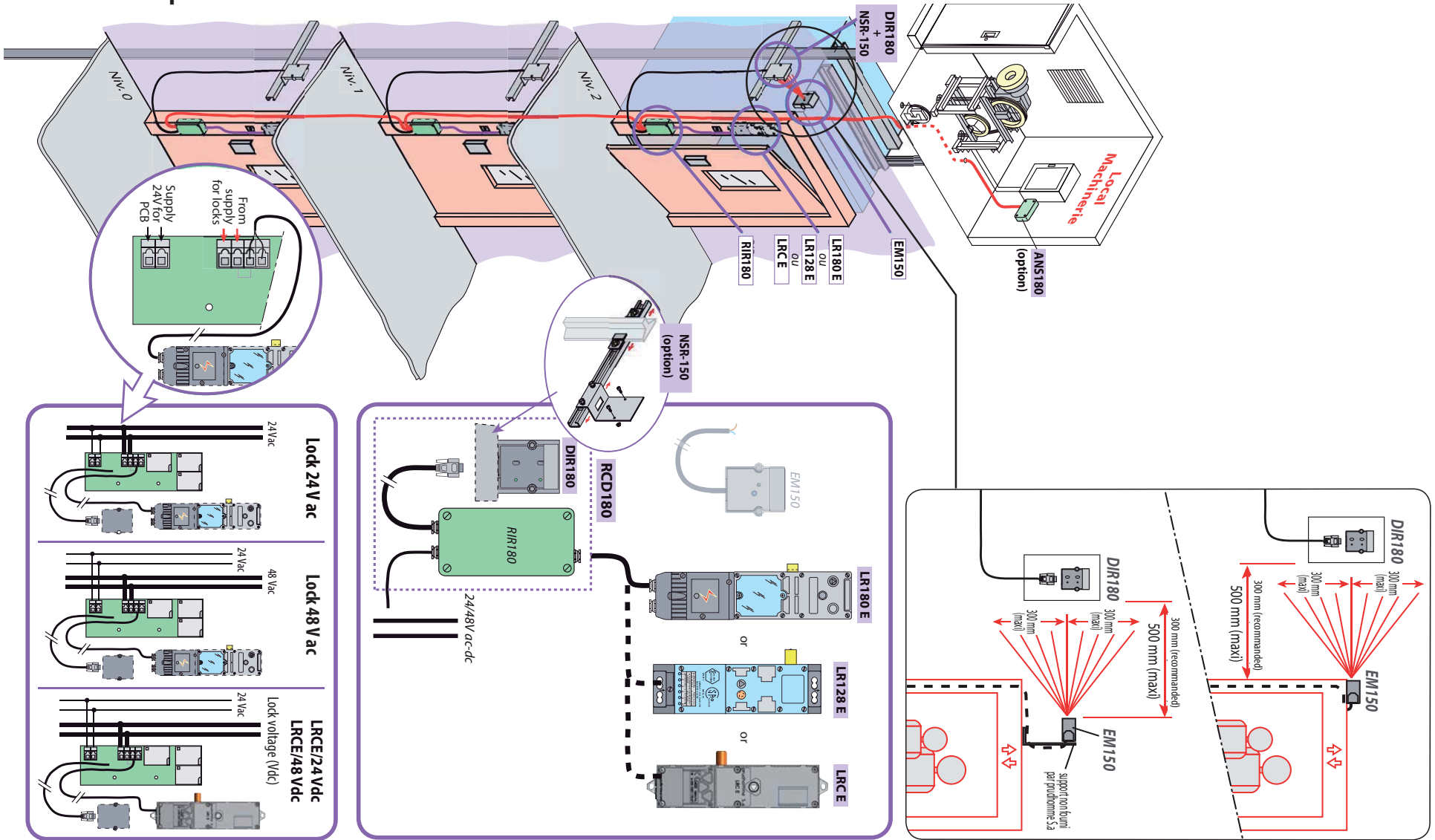

Lock LRCE Accessories

réf. **GV-LRC**

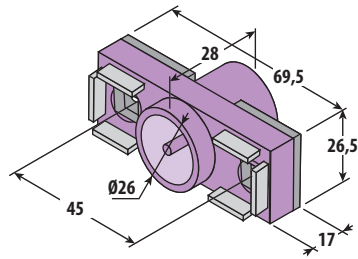

The adjustment is carried out on the 2 captive nuts for fixing.

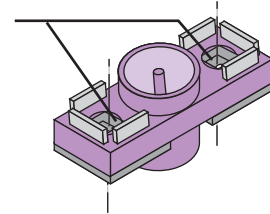

GV-LRC lock-keeper installation

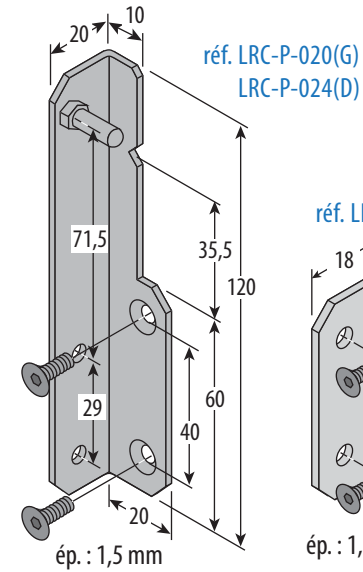
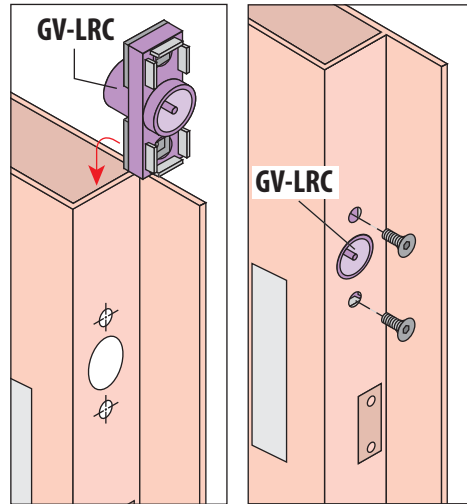

réf. **LRC-P-026**

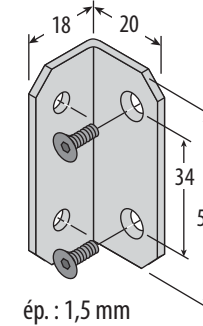

réf. **SHD21**
SHD18
SHD25

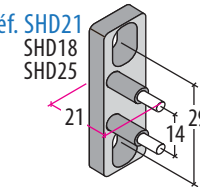

réf. **GVR-LRC**

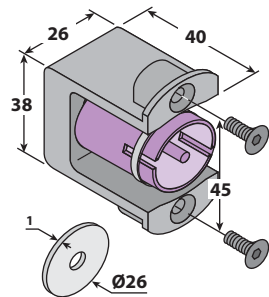

réf. **LL6**

Lock-keeper GVR-LRC installation

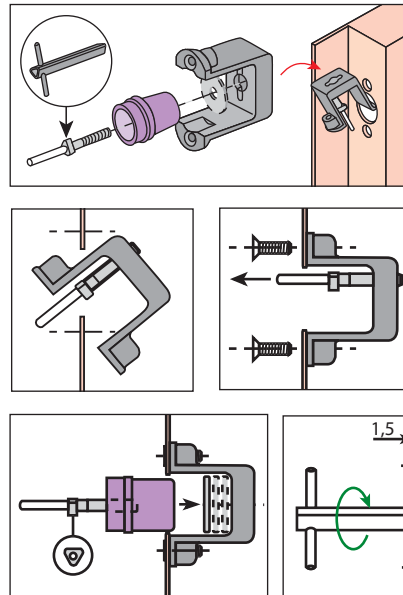

Lock-keeper GVR-LRC adjustment

The GVR lock-keeper adjustment is possible with a triangular key

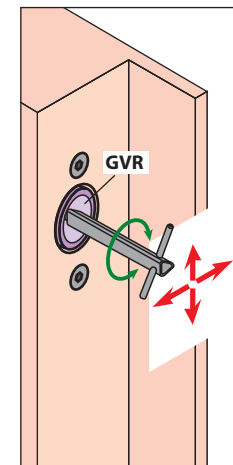

**DECLARATION UE DE CONFORMITE POUR COMPOSANTS DE SECURITE
EU DECLARATION OF CONFORMITY FOR SAFETY COMPONENTS
ERKLARUNG ZUR EU UBEREINSTIMMUNG VON SICHERHEIT KOMPONENTEN**

Nom et adresse du fabricant et du détenteur de la déclaration :

Manufacturers' and holder's

Certificate name and address :

Name und adresse von Hersteller und Erklarung besitzer :

prudhomme S.a

38, rue Charles de Gaulle

94140 Alfortville

(FRANCE)



Catégorie, type et marque de fabrique ou de commerce :

Category, type and make or Trade name :

Kategorie, Typ und Fabrik-oder Handelsmarke :

- Serrure d'ascenseurs à sécurité positive type LRC 260 & LRC E pour porte battante ou coulissante 1 vantail

- Positive safety lock type LRC 260 & LRC E for simple hinged or sliding doors

- Positiv sicherheit Türverschluss LRC260 & LRC E für Schwenk oder Schiebetür

Année de fabrication :

Years of manufacture :

Baujahr :

2023

Nom et adresse et numero de référence de l'organisme notifié :

Name, address and reference number of the notified organism :

Name, Adresse und Referenz-Nummer von der deklarierten Instanz :

LIFTINSTITUUT B.V.

Buikslotermeerplein 381

1025 XE - P.O. Box 36027

1020 MA - AMSTERDAM

N° 0400

Attestation de type :

Ce composant a obtenu l'attestation d'examen CE de type NL 16-400-1002-125-07, Rev01, Rev.2, délivré par le LIFTINSTITUUT B.V.

Type Examination Certificate :

The component is declared in conformity with the EC type NL 16-400-1002-125-07, Rev01, Rev.2, delivered by the LIFTINSTITUUT B.V.

Art der Bescheinigung :

Diese Komponente hat die Bescheinigung EG NL 16-400-1002-125-07, Rev01, Rev.2, erhalten.

Nom et adresse et numero de référence de l'organisme notifié pour la validation du système d'assurance qualité production :

Name, address and reference number of the notified organism for the validation of the quality insurance system :

Name, Adresse und Referenz-Nummer von der deklarierten Instanz / für die Erklärung des Qualitäts-Versicherungs-Systems :

Bureau Veritas

67-71, Boulevard du Château

92200 Neuilly sur seine - France

N° 2681-LD-VI-PR2 001-17-FRA (Annexe VI)

Norme :

Ce composant répond à la Directive ascenseur : 2014/33/UE

Ce composant répond à la norme : EN 81-1/2: 1998 + A3: 2009 ainsi qu'à la EN 81-20/50: 2020

Standard :

This component meets the Lift Directive 2014/33/UE

This component meets the standard: EN 81-1/2: 1998 + A3: 2009 as well as EN 81-20/50: 2020

Norm :

Diese Komponente entspricht der Richtlinie Aufzug 2014/33/UE

Diese Komponente erfüllt die Norm: EN 81-1/2: 1998 + A3: 2009 sowie EN 81-20/50: 2020

Roland TRICOT

Directeur Général

General Manager / CEO

Date : 22-1-2023

Lieu : Paris FRANCE

DECLARATION UE DE CONFORMITE POUR COMPOSANTS DE SECURITE
DECLARACIÓN DE CONFORMIDAD UE PARA COMPONENTES DE SEGURIDAD
DICHIARAZIONE DI CONFORMITÀ UE PER COMPONENTI DI SICUREZZA
DECLARAÇÃO UE DE CONFORMIDADE PARA COMPONENTES DE SEGURANÇA

Nom et adresse du fabricant et du détenteur de la déclaration :
Nombre y dirección del fabricante y del titular de la declaración :
Nome e indirizzo del fabbricante e del titolare della dichiarazione :
Nome e morada do fabricante e do detentor da declaração :

prudhomme S.a
38, rue Charles de Gaulle
94140 Alfortville
(FRANCE)



Catégorie, type et marque de fabrique ou de commerce :

- Serrure d'ascenseurs à sécurité positive type LRC 260 & LRC E pour porte battante ou coulissante 1 vantail

Categoría, tipo y marca de fábrica o de comercio :

- Cerradura de seguridad positiva tipo LRC 260 & LRC E para puerta batiente o corredera

Categoria, tipo e marchio di fabbrica o nome commerciale :

- Serratura di ascensori a sicurezza positiva tipo LRC 260 & LRC E per porta battente o scorrevole 1 stoffa per tendin

Categoria, tipo e marca de fabrico ou comercial :

- Fechadura de ascensores de segurança positiva tipo LRC 260 & LRC E para porta de tipo batente o correção 1 batente

Année de fabrication :

2023

Año de fabricación :

Anno di fabbricazione :

Ano de fabrico :

Nom et adresse et numero de référence de l'organisme notifié :

LIFTINSTITUUT B.V.

Nombre y dirección y número de referencia del organismo notificado :

Buikslotermeerplein 381

1025 XE - P.O. Box 36027

1020 MA - AMSTERDAM

Nome ed indirizzo e numero di riferimento dell'organismo notificato :

N° 0400

Nome e endereço e número de referência do organismo notificado :

Attestation de type :

Ce composant a obtenu l'attestation d'examen CE de type NL 16-400-1002-125-07, Rev01, Rev.2, délivré par le LIFTINSTITUUT B.V.

Certificado de tipo :

Este componente ha obtenido el certificado de examen CE de tipo NL 16-400-1002-125-07, Rev01, Rev.2, expedido por el LIFTINSTITUUT B.V.

Attestazione di tipo :

Questo componente ha ottenuto l'attestazione di conformità CE di tipo NL 16-400-1002-125-07, Rev01, Rev.2, rilasciata da LIFTINSTITUT B.V.

Certificado de Exame de tipo :

Este componente obteve o certificado de exame CE de tipo NL 16-400-1002-125-07, Rev01, Rev.2, fornecido pelo LIFTINSTITUUT B.V.

Nom et adresse et numero de référence de l'organisme notifié pour la validation du système d'assurance qualité production :

Bureau Veritas

67-71, Boulevard du Château

92200 Neuilly sur seine - France

Nombre y dirección y número de referencia del organismo notificado para la validación del sistema de garantía de calidad :

N° 2681-LD-VI-PR2 001-17-FRA (Annexe VI)

Nome ed indirizzo e numero di riferimento dell'organismo notificato per la convalida del sistema d'assicurazione qualità :

Nome e endereço e número de referência do organismo notificado para a validação do sistema de seguro qualidade :

Norme :

Ce composant répond à la Directive ascenseur : 2014/33/UE

Norma :

Ce composant répond à la norme : EN 81-1/2: 1998 + A3: 2009 ainsi qu'à la EN 81-20/50: 2020

Roland TRICOT

Directeur Général

Director General

Director-Geral

Date :

22-1-2023

Lieu :

Paris FRANCE

Este componente responde a la Directiva Ascensor 2014/33/UE

Este componente se encuentra con la norma EN 81-1/2: 1998 + A3: 2009, así como con la norma EN 81-20/50 2020

Questo componente a conforme alla Direttiva Ascensori 2014/33/UE

Questo componente è conforme alla norma EN 81-1/2: 1998 + A3: 2009, nonché alla EN 81-20/50 2020

Este componente cumpre a directiva elevador: 2014/33/UE

Este componente cumpre a norma: EN 81-1/2: 1998 + A3: 2009, bem como a EN 81-20/50 2020



liftinstituut
SINCE 1933



EU-TYPE EXAMINATION CERTIFICATE

Issued by Liftinstituut B.V.
identification number Notified Body 0400,
commissioned by Decree no. 2022-0000107366

Certificate no. : NL16-400-1002-125-07 Revision no.: 2

Description of the product : Compact door locking device for manually operated hinged landing doors

Trademark : Prudhomme S.a.

Type no. : LRC 260 & LRC E

Name and address of the manufacturer : Prudhomme S.a.
38 rue Charles de Gaulle
94140 Alfortville
France

Name and address of the certificate holder : Prudhomme S.a.
38 rue Charles de Gaulle
94140 Alfortville
France

Certificate issued on the following requirements : Lifts Directive 2014/33/EU

Certificate based on the following standard : Parts of: EN 81-20:2020, EN 81-50:2020

Test laboratory : None

Date and number of the laboratory report : None

Date of EU-type examination : January 2023

Additional document with this certificate : Report belonging to the EU-type examination certificate no.: NL16-400-1002-125-07 Rev.2

Additional remarks : Max. rated voltage 250 VAC
Max. rated current 2,0 A
Furthermore see chapter 5 of the report belonging to this EU-type examination certificate.
This revision replaces certificate NL16-400-1002-125-07 Rev.1 of 19-04-2018

Conclusion : The safety component meets the requirements of the Lifts Directive 2014/33/EU taking into account any additional remarks mentioned above.

Certification decision by

W.G. Kasteleijn
Product Manager Certification

Amsterdam

Date : 16-01-2023

Valid until : 16-01-2028



liftinstituut
SINCE 1933



Report EU-type examination

Report belonging to EU-type examination certificate number	: NL16-400-1002-125-07
Date of issue of original certificate	: February 14, 2017
Certificate applies to	: Safety component
Revision number / date	: 2 / January 16, 2023
Requirements	: Lifts Directive 2014/33/EU Standards: EN81-20:2020, EN81-50:2020
Project number	: P220386

1. General specifications

Description of the product	: Compact door locking device for swing doors
Trademark	: Prudhomme S.a.
Type no.	: LRC 260 & LRC E
Name and address of the manufacturer	: Prudhomme S.a. 38 rue Charles de Gaulle 94140 Alfortville, France
Laboratory	: None
Address of examined component	: Liftinstituut, Amsterdam, The Netherlands
Date of examination	: January 2023
Examination performed by	: M. Issa

2. Description safety component

The LRC 260 compact locking device can be used for hinged landing doors and is equipped with a lateral lever (LG), a perpendicular lever (PG), a Bowden cable operation (CG) or any outside lever operation (LkG, C1G). The difference between these versions of the locking devices is the way of operating the rod that is connected to the locking pin.



The LRC E compact locking device can be used for hinged landing doors and is operated electrically, without a mechanical lever. A motor is operating the locking pin. Opening movement of the locking pin is limited by a switch inside the housing that reduces the motor current to a holding current.

The locking takes place by a pin, with an inclined part, in a hole in the side of the landing door. The locking pin can be located on either side of the locking housing.

Actual locking is performed by a guided spring, moving the locking pin outwards.

There are two types of internal mechanism and corresponding locking pins, which slightly differ:

-Inside the housing a checking pin is provided to check if the landing door is properly closed. If the pin gets stuck the door lock contact won't close, or

-Inside the locking pin a checking pin is provided to check if the landing door is properly closed. If the pin gets stuck the door lock contact won't close.

The housing of the lock is made from die-cast. The top side is fitted with a partially transparent cover, so contacts and locking components can be inspected without removing any covers.

Also is it possible to open both lock types by means of a triangular key according Fig. 13 of EN81-20 from the landing side. The LRC E lock can also be opened from the well side by the triangular key.

The used locking contact is the following:

Manufacturer	Prudhomme S.a.
U _e / I _e	250 VAC / 2,0 A AC

For LRC E the following motor can be used:

Manufacturer	Prudhomme S.a.
U _e / I _e / Holding Current	12-24-48 VDC / 0,2-0,15-0,15 ADC

See annex 1 for a general overview of the product

3. Examinations and tests

The examination covered a check whether compliance with the Lift Directive 2014/33/EU is met, based on the harmonized product standards EN 81-20:2020 and EN 81-50:2020.

The examination included:

- Examination of the technical file (See annex 2):
- Examination of the representative model in order to establish conformity with the technical file.
- Inspections and tests to check compliance with the requirements.



The tests which are performed are as stated in clause 5.2 of EN 81-50.
The mechanical and electrical tests are performed on the LRC-E-015 locking device. This is a locking device with the checking pin integrated in the locking pin and has a perpendicular unlocking arm.
Additionally, only mechanical tests are performed on the LRC-E-030 locking device. This is a locking device with the checking pin in the back side of the lock housing and has a lateral unlocking arm.
For all different subtypes the locking contact and its operation by internal mechanism is identical.

3.1 Mechanical tests

Endurance test

According clause 5.2.2.2.2 of EN 81-50 an endurance test must be made. For this test a special testing apparatus was designed. With 60.0 rpm the actuator rod was driven. A mechanical counter was installed to keep track of the number of cycles.

Test details for LRC-E-015

Start date / time January 26th, 2017 / 14:15
End date / time February 07th, 2017 / 15:00
Number of cycles >1.000.000

Test result: OK

Test details for LRC-E-030

Start date / time January 25th, 2017 / 09:00
End date / time February 7th, 2017 / 05:15
Number of cycles >1.000.000

Test result: OK

Static test

According clause 5.2.2.2.3 of EN 81-50 a static test must be made. To perform the static test a weight was linked to the locking pin. Because the difference between both locking pins, this test was performed on both locking devices.

Test details for LRC-E-015

Test date February 09th, 2017
Test weight 3000N increasing progressively for 300 seconds.

Test result: OK

Test details for LRC-E-030

Test date February 09th, 2017
Test weight 3000N increasing progressively for 300 seconds.



liftinstituut
SINCE 1933



Test result: OK

Dynamic test

According to clause 5.2.2.2.4 of EN 81-50 a dynamic test must be made. To perform the dynamic test a block was dropped on the locking pin. The dropping distance was 50 cm. Because the difference between both locking pins, this test was performed on both locking devices.

Test details for LRC-E-015

Test date February 09th, 2017
Test weight 4 kg
Dropping distance 50 cm

Test result: OK

Test details for LRC-E-030

Test date February 09th, 2017
Test weight 4 kg
Dropping distance 50 cm

Test result: OK

3.2 Electrical tests

Endurance test,

The locking contact was tested during the endurance test of LRC-E-015. The contact was connected to a resistive circuit.

Test details for locking contact

Number of cycles 1037330
Test voltage $1,0 \times U_e = 250 \text{ V}$
Test current $2,0 \times I_e = 4.0 \text{ A}$

Test Result: OK

Test of ability to break circuit

In accordance with 60947-5-1 a circuit was made with a resistor and choke in series.

Test details for locking contact

Test voltage $1,1 \times U_e = 275 \text{ VAC}$
Test current $11 \times I_e = 22,0 \text{ A}$
Cos φ $0,7 = 45^\circ$
Number of cycles 50 at 6-12 rpm

Test Result: OK



Test to determine degree of Protection

According to clause 5.11.2.2.1 of EN 81-20 the degree of protection must be IP4X. The clearance shall be at least 3 mm, the creepage distances at least 4 mm and the distances for breaking contacts at least 4 mm after separation.

Test result: OK

Examination of clearances and creepage distances

According to clause 5.11.2.2.4 of EN 81-20 the clearance shall be at least 3 mm, the creepage distances at least 4 mm and the distances for breaking contacts at least 4 mm after separation.

Test result: OK

Test for resistance of leakage currents

This test is not performed but based on the values from prior tests made by the manufacturers supplier these values go beyond the requirements of the EN81-50, clause 5.2.2.4.3. The CTI value for Lexan 940A, that is used for the transparent cover, is 225. The CTI value for Lexan 500R, that is used for the locking contact isolator, is 175. The minimum value requested according to the mentioned clause is 175. Also different literature confirm these values.

Revision 1: adding the LRC E locking device:

The tests which are performed are as stated in clause 5.2 of EN 81-50.

The mechanical and electrical tests are performed on the LRC-E-049 locking device.

This is a locking device with the checking pin in the back side of the lock housing and has a 24 VDC unlocking motor.

Additionally, only mechanical tests are performed on the LRC-E-067 locking device.

This is a locking device with the checking pin integrated in the locking pin and has a 24 VDC unlocking motor. The locking pin has an additional length of 35 mm.

For all different subtypes the locking contact and its operation by internal mechanism is identical.

3.1 Mechanical tests

Endurance test

According clause 5.2.2.2.2 of EN 81-50 an endurance test must be made. For this test a special testing apparatus was designed. With 60.0 rpm the actuator rod was driven. A mechanical counter was installed to keep track of the number of complete cycles.

Test details for LRC-E-049

Start date / time	April 5 th , 2018 / 13:50
End date / time	April 17 th , 2018 / 12:20
Number of cycles	>1.000.000



liftinstituut
SINCE 1933



Test result: OK

Test details for LRC-E-067

Start date / time April 5th, 2018 / 09:15
End date / time April 19th, 2018 / 07:00
Number of cycles >1.000.000

Test result: OK

Static test

According to clause 5.2.2.2.3 of EN 81-50 a static test must be made. To perform the static test a weight was linked to the locking pin. Because of the difference between both locking pins, this test was performed on both locking devices.

Test details for LRC-E-049

Test date April 19th, 2018
Test weight 3000N increasing progressively for 300 seconds.

Test result: OK

Test details for LRC-E-067

Test date April 19th, 2018
Test weight 3000N increasing progressively for 300 seconds.

Test result: OK

Dynamic test

According to clause 5.2.2.2.4 of EN 81-50 a dynamic test must be made. To perform the dynamic test a block was dropped on the locking pin. The dropping distance was 50 cm. Because of the difference between both locking pins, this test was performed on both locking devices.

Test details for LRC-E-049

Test date April 19th, 2018
Test weight 4 kg
Dropping distance 50 cm

Test result: OK

Test details for LRC-E-067

Test date April 19th, 2018
Test weight 4 kg
Dropping distance 50 cm

Test result: OK



3.2 Electrical tests

Endurance test,

The locking contact was tested during the endurance test of LRC-E-049.
The contact was connected to a resistive circuit.

Test details for locking contact

Number of cycles 1000100
Test voltage $1,0 \times U_e = 250 \text{ V}$
Test current $2,0 \times I_e = 4.0 \text{ A}$

Test Result: OK

Test of ability to break circuit

In accordance with 60947-5-1 a circuit was made with a resistor and choke in series.

Test details for locking contact

Test voltage $1,1 \times U_e = 275 \text{ VAC}$
Test current $11 \times I_e = 22,0 \text{ A}$
Cos φ $0,7 = 45^\circ$
Number of cycles 50 at 6-12 rpm

Test Result: OK

4. Results

After the final examination the product and the technical file were found in accordance with the requirements. The functional tests passed without remarks.

5. Conditions

Additional to or in deviation of the applicable demands in the considered requirements / standards (see certificate and/or page 1 of this report), the following conditions shall be taken into account:

- The door lock shall be used for swing doors only.
- The door locking device shall be applied within rated current and voltage
2.0 A / 250 VAC
- The installation and maintenance instructions shall be provided with the lock.
- Max. door gap at locking side shall be 12.0 mm and 15.5 mm for the locks with long bolts.



liftinstituut
SINCE 1933



- Locking distance before making contact must be at least 7 mm.
- The position of the unlocking triangle shall be according to clause 5.3.9.3.2 of EN 81-20.
- The position of the LRC E door lock at the bottom landing door shall be such, that the requirements of clause 5.3.9.3.5 of EN81-20 are met.
- For the LRC E locking device it shall be ensured by mechanically forced interlocked switches (safety contacts) or by the lift control unit with safety circuit comprising two channels, that only the landing door is being unlocked behind of which the car is positioned (unlocking zone).

6. Conclusions

Based upon the results of the EU-type examination Liftinstituut B.V. issues an EU-type examination certificate.

The EU-type examination certificate is only valid for products which are in conformity with the same specifications as the type certified product. The certificate is issued based on the requirements that are valid at the date of issue. In case of changes of the product specifications, changes in the requirements or changes in the state of the art the certificate holder shall request Liftinstituut B.V. to reconsider the validity of the certificate.



liftinstituut
SINCE 1933



7. CE marking and EU Declaration of conformity

Every safety component that is placed on the market in complete conformity with the examined type must be provided with a CE marking according to article 18 of the Lift directive 2014/33/EU under consideration that conformity with eventually other applicable Directives is proven. Also every safety component must be accompanied by an EU declaration of conformity according to annex II of the Directive in which the name, address and Notified Body identification number of Liftinstituut B.V. must be included as well as the number of the EU-type examination certificate.

An EU type-certified safety component shall be random checked e.g. according to annex IX of the Lift directive 2014/33/EU before these safety components may be CE-marked and may be placed on the market. For further information see regulation 2.0.1 'Regulations for product certification' on www.liftinstituut.com.

Prepared by:

Mohamed Issa
Product Specialist Certification

Certification decision by:

W.G. Kasteleijn
Product Manager Certification



Annexes

Annex 1.a Door locking device LRC260/PG (E-014)

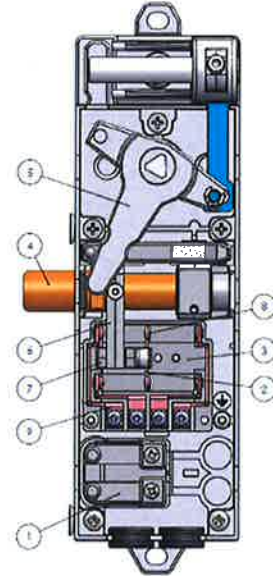

Annex 1b : Door locking LRC260/PG (E-015)

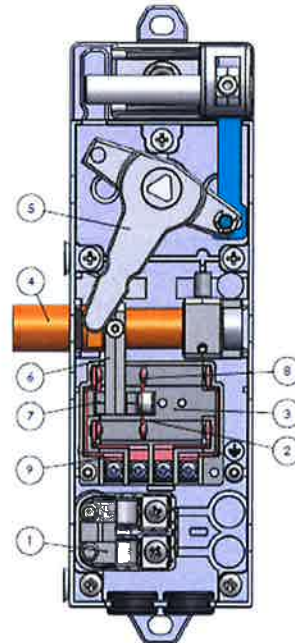



Annex 1c : Door locking LRC260/LG (E-030)

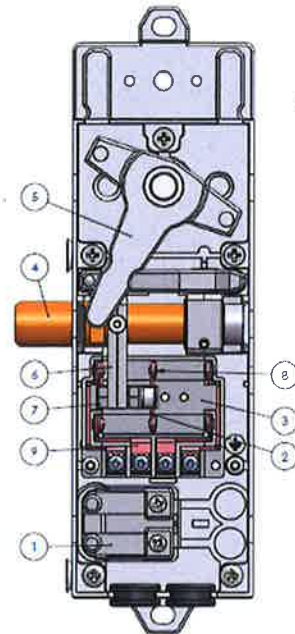

Annex 1d : Door locking LRC260/LG (E-031)

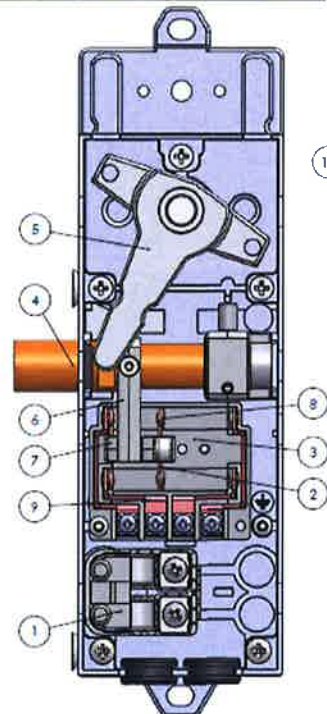



liftinstituut
SINCE 1933



Annex 1g : Door locking LRC260/LcK (E-047)

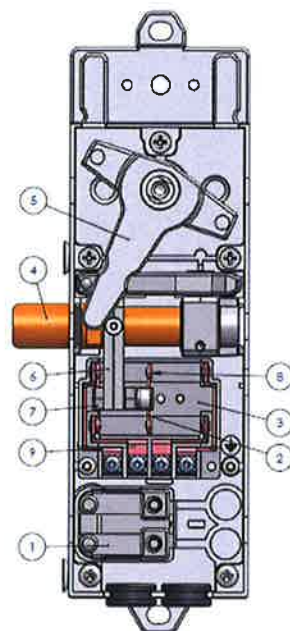
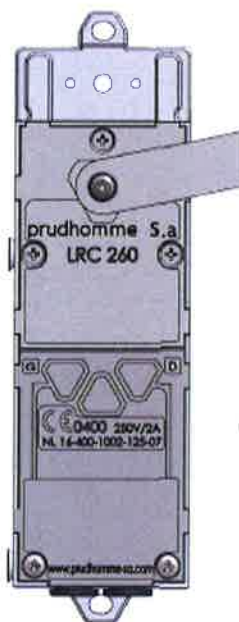

Annex 1h : Door locking LRC260/C1G (E-048)

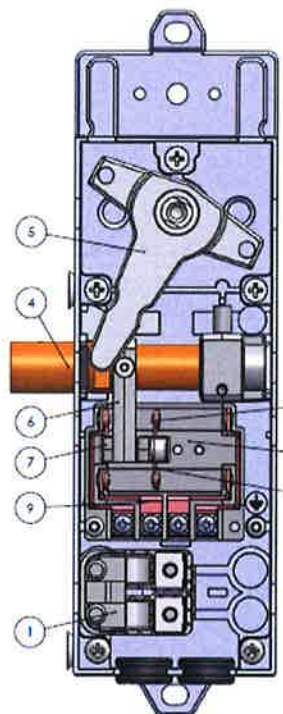



Annex 1i : Door locking device LRC E (E-049)

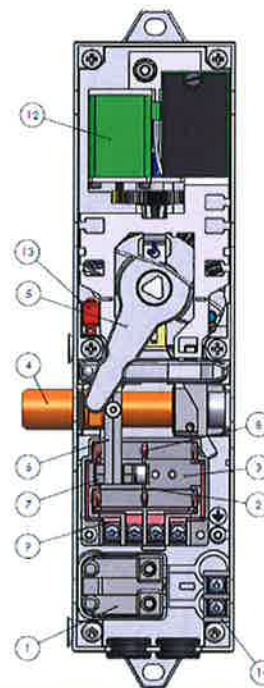

Annex 1j : Door locking LRC E (E-054)

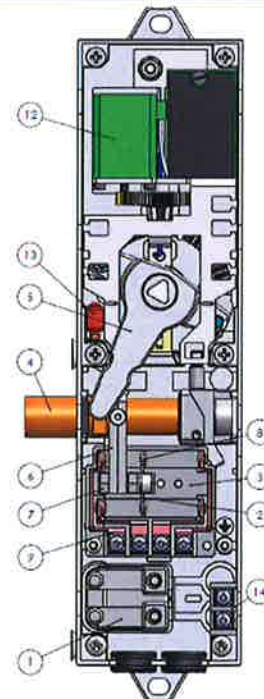



Annex 1k : Door locking LRC E (E-067) (Long Bolt)

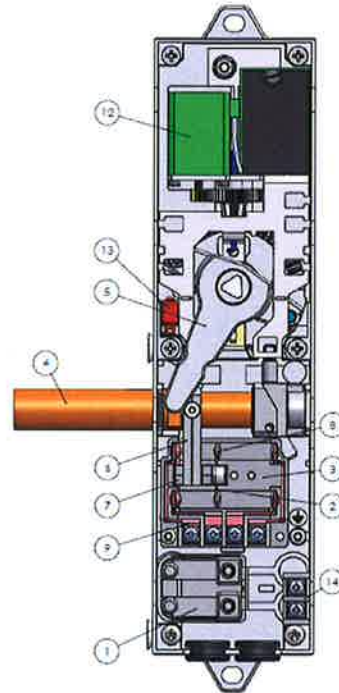

Annex 1l : Checking pin at back of housing

Bolt in support on the hook's 1st notch

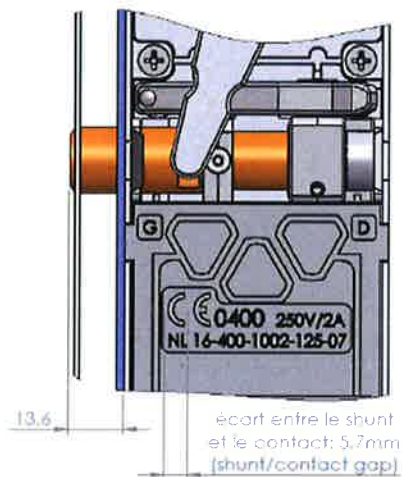

Bolt in support on the hook's 2nd notch

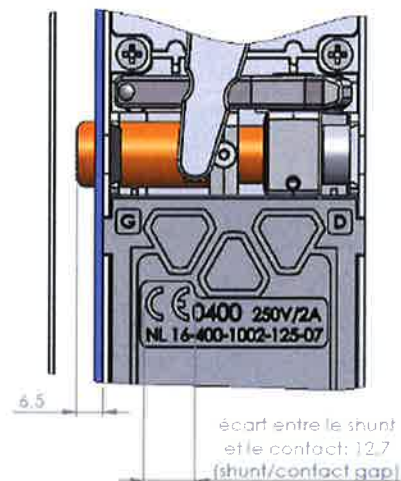



Annex 1m : Checking pin integrated in locking pin

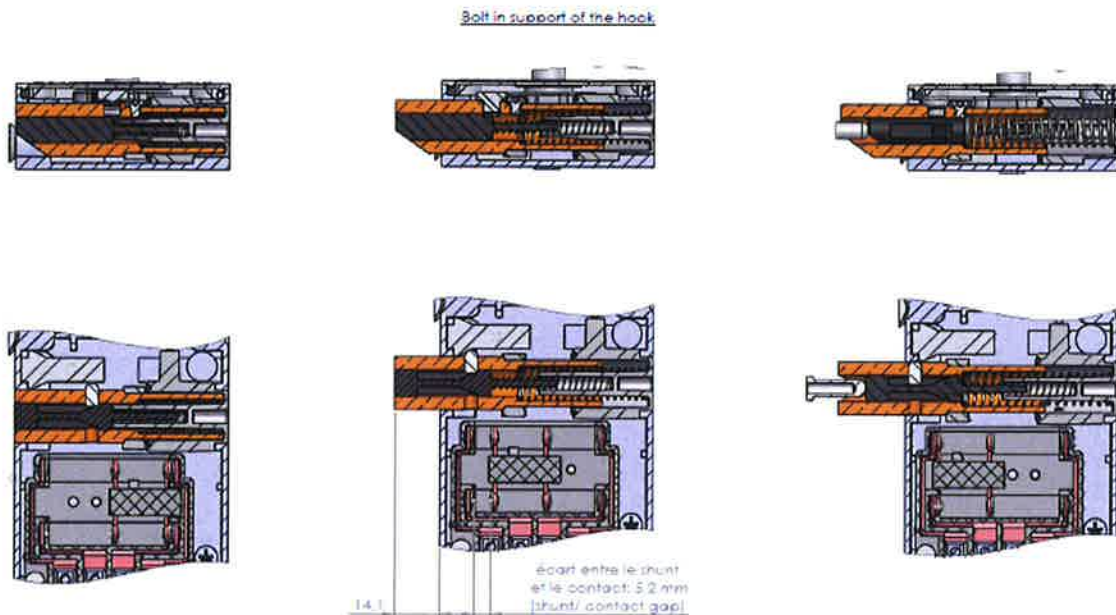

Annex 1n : Checking pin integrated in locking pin, long bolt

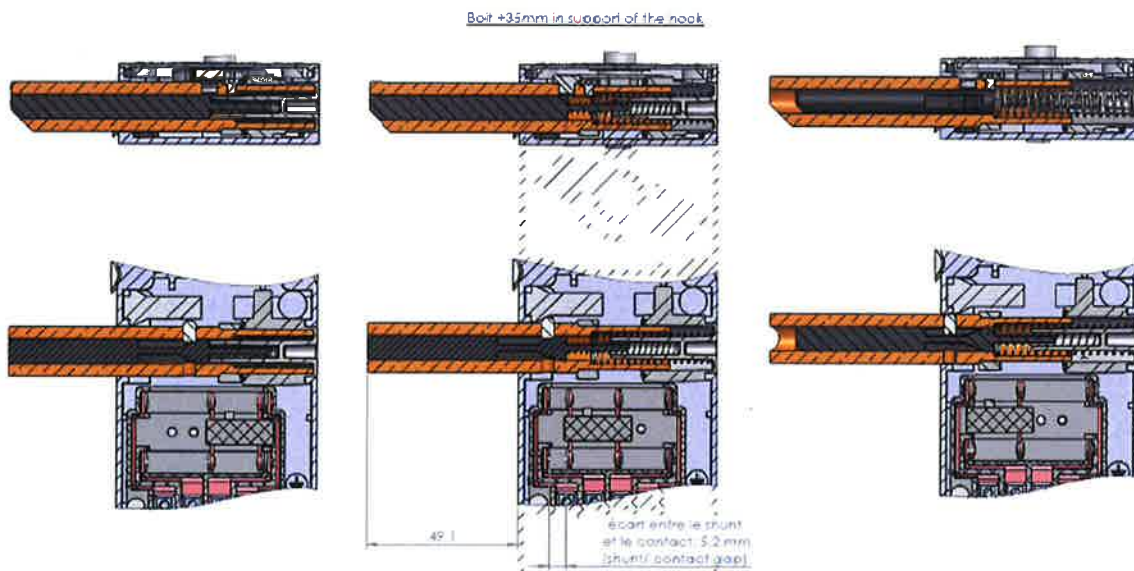



Annex 2. Documents of the Technical File which were subject of the examination

Title	document number	date
LRC260-PG	LRC-E-014	28-10-2016
LRC260-PG	LRC-E-015	20-04-2016
LRC260-LG	LRC-E-030	26-10-2016
LRC260-LG	LRC-E-031	20-04-2016
LRC260-CG	LRC-E-045	28-10-2016
LRC260-CG	LRC-E-046	20-04-2016
LRC260-LkG	LRC-E-047	26-10-2016
LRC260-C1G	LRC-E-048	20-04-2016
LRC E Percussion latérale	LRC-E-049	18-01-2018
LRC E Percussion centrale	LRC-E-054	18-01-2018
LRC E Percussion centrale & pêne + 35 mm	LRC-E-067	18-01-2018
Installation manual LRC260	Ver.A	17-02-2017
Installation manual LRCE	Ver.A	25-08-2020

Annex 3. Reviewed deviations from the standards

EN xx-x par.	Requirement	Accepted design
x.x.x		

Annex 4. Revision of the certificate and its report

Rev.:	Date	Summary of revision
-	14-02-2017	Original
1	19-04-2018	Added LRC E locks
2	16-01-2023	Certification renewal. Standard version updated. Annex 2 updated.

End of report